

# airdome 150





Committed to enhancing air quality in today's uncertain times, Trident Air's product range stands as a significant advancement in creating a healthier, safer world.

Breathe Like It's the Outdoors, at Home.



## TABLE OF CONTENTS

- INTRODUCTION..... 4
- INSTALLATION AND SETUP .....7
- PRODUCT..... 8
- ASSEMBLY..... 8
- WI-FI CONNECTION..... 9
- OPERATING INSTRUCTIONS .....10
- MAINTENANCE AND CLEANING ..... 12
- TROUBLESHOOTING..... 14
- AIR QUALITY COLOUR DISPLAY..... 14
- TECHNICAL SPECIFICATIONS..... 15
- CUSTOMER SERVICE AND WARRANTY INFORMATION ..... 15

Welcome to your new

## Trident AirDome™ 150 Purifier — a state-of-the-art air purification system.

It is armed with Trident AirDome™ Technology, developed in collaboration with the Agency for Science, Technology and Research (A\*STAR) Singapore to ensure your environment remains clean, purified and healthy.

A proprietary process that replicates the germicidal properties of natural air, maintaining a balanced composition of bipolar ions for a revitalised environment.

Destroys viruses in less than 15 minutes, well before they can infect you. It's 3x faster than the next best option in the market.

Washable Air CAGE™ filters ensure trapped mould, mites, or dust do not recirculate in the air, ensuring 24/7 total air purity.

This manual provides comprehensive instructions for the setup, use, and care of your air purifier. Please read through these instructions carefully to maximise the effectiveness of your AirDome™ Purifier.



## AirDome™ Technology

### Active Air Circulation and Extermination of Pathogens

Get Total Indoor Air Sanitisation, Purification and Protection.

Backed by the most rigorous scientific research and development, and tested to exacting standards. Technology fit for mission critical institutions, now made for your home.

# Greater than sum of its parts

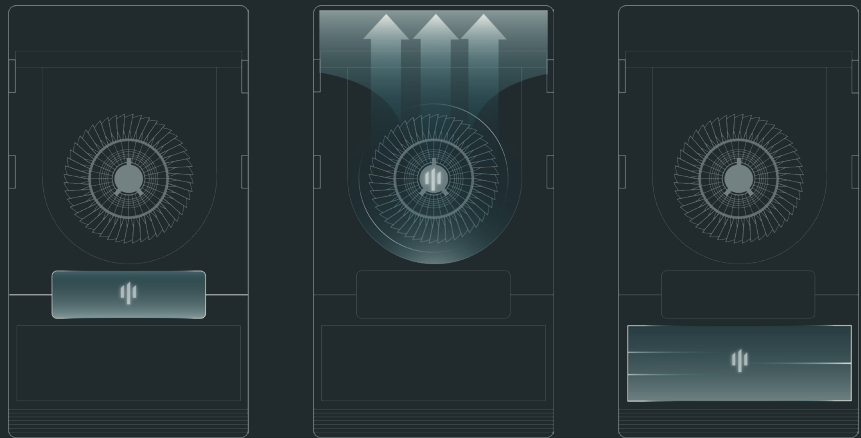

Trident Air Activator™

Trident Air Circulator™

Trident Air CAGE™ Filters

Trident takes the sum of all three key technologies and amplifies their power. It generates a full-environmental shield—an invisible air dome—in any indoor space it's deployed in. It is technology so advanced it blankets any surface in baby- and food-safe ions that destroy germs upon contact.

There's nothing quite like it.

## INSTALLATION AND SETUP

Trident AirDome™ 150	1 pc
Trident Washable Dust Filter	2 pcs
Trident Washable Air CAGE™ Filter	2 pcs
Trident Carbon Ozone Filter (DO NOT WASH with water)	2 pcs
Trident Air Activator™	1 pc

### Unpacking:

Verify all items listed on the packing list are included. Position the purifier near a power source, ensuring the air intake and outlet are free from obstructions.

### Power Connection:

Connect the device to an electrical outlet that matches the specifications listed under Technical Specifications.

Your AirDome™ Purifier uses advanced AirDome™ Technology: equipped with proprietary Air Activator™, Air Circulator™ and Air CAGE™ filters that work in synergy to revitalise indoor air.

Learn more online at [www.tridentair.com/airdome](http://www.tridentair.com/airdome)

## PRODUCT & ACCESSORIES

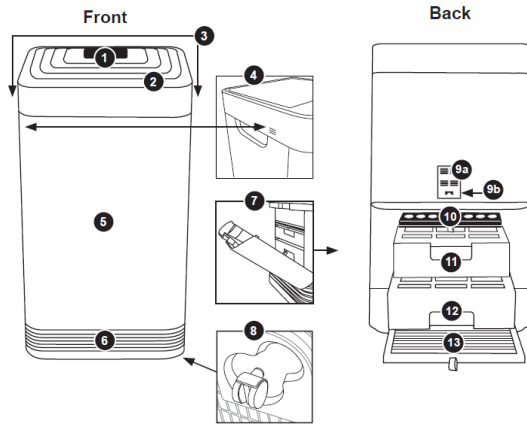

1	Air Outlet Vent	8	Wheels
2	Front Display Touchpad Panel	9	Sensor Cover, PM2.5 Sensor
3	Handles	10	Carbon Ozone Filter
4	TVOC Sensor	11	Washable Air CAGE™ Filter 2
5	Base	12	Washable Air CAGE™ Filter 1
6	Air Inlet Vent	13	Washable Dust Filter
7	Filter Slot Cover		

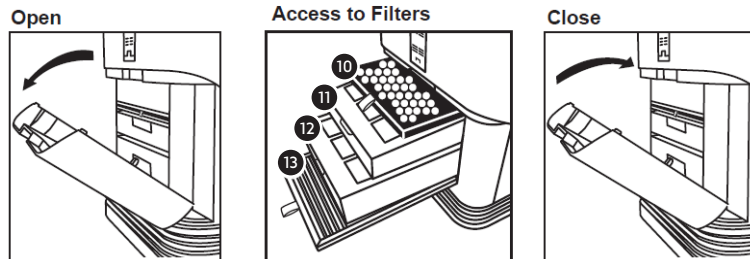

## WI-FI CONNECTION

1. Download the “Smart Life” app via the QR Code, or search for the “Smart Life” app on the App Store or Google Play Store.



2. Launch the App and select “Register” to create an account with “Smart Life” using your phone number or email address to log in.

3. Press and hold on the Auto button to activate the WiFi on AirDome™ 150.

4. Do ensure that your phone’s WiFi is connected to 2.4GHz, instead of 5.0GHz, prior to “add device”.

5. On the app, click “add device” or press “+” in the top right corner of the homepage.

6. There are two ways to access the “add device” page: manually adding WiFi or automatically search for devices.

a. When adding a device manually, select any product from the product ring to enter a new homepage and make sure the indicator light flashes quickly.

b. Ensure that both your phone and smart gadget are powered on and linked to your WiFi. If the WiFi indicator on AirDome™ 150 does not flash, please press and hold the button again for at least 3 seconds until the indicator light begins to flash rapidly, indicating AirDome™ 150 is ready for configuration.

# OPERATING INSTRUCTIONS

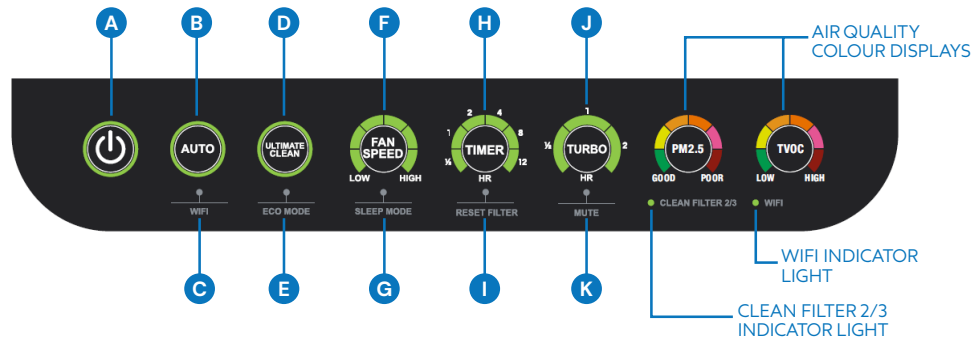

## OPERATING BUTTONS

- A Power On/Off**
1. Plug your AirDome™ 150 into an outlet. The **POWER** button will be lit red for standby mode.
  2. Press **POWER**. The AirDome™ 150 will turn on and the **POWER** button will be lit green.
    - Each bar around PM2.5 and TVOC will illuminate, this is measuring current air quality while the fan is on.
  3. Press **POWER** again to turn the AirDome™ 150 off.
    - When you select a different mode other than the default AUTO before turning off, the AirDome™ 150 will run the previously selected mode when it is powered back on.
- B Auto**
- Allows your AirDome™ 150 to adjust the fan speed automatically (No time limit, cannot run with Fan Speed and Ultimate Clean).
1. Press **AUTO**. The **AUTO** light will be lit.
  2. Press **AUTO** again to turn off function.
- C Wifi**
- Allows you to connect the AirDome™ 150 to your Wi-Fi network. Press and hold **AUTO** to initiate Wi-Fi pairing function. See page 9 for details.
- D Ultimate Clean**
- Allows your AirDome™ 150 to automatically adjust to the highest fan speed based on your air quality. (No time limit, cannot run with Auto).
1. Press **ULTIMATE CLEAN**. The **ULTIMATE CLEAN** light will be lit green.
  2. Press **ULTIMATE CLEAN** again to turn it off.
- E Eco Mode**
- Allows you to save energy by keeping the AirDome™ 150 fan off until it's needed. The **POWER** button will be lit yellow.
1. Press and hold **ULTIMATE CLEAN** for 2 seconds to activate. The Power icon backlight will be yellow while **ECO MODE** is on.
  2. Press and hold **ULTIMATE CLEAN** for 2 seconds again to deactivate **ECO MODE**.

- F Fan Speed**
- Allows you to adjust the AirDome™ 150 fan speed to 6 different speeds (LOW to HIGH). (Cannot run with Auto and Turbo).
1. Press **FAN SPEED** to adjust.
  2. To go back to the lowest fan speed, press **FAN SPEED** until the first green bar is lit.

- G Sleep Mode**
- Allows your AirDome™ 150 fan to still be active while the LED lights are turned off. Adjust the fan speed to your preference prior to turning on sleep mode.
3. Manually set **FAN SPEED** to desired setting.
  4. Press and hold **FAN SPEED** for 2 seconds again to activate **SLEEP MODE**.
  5. To turn off **SLEEP MODE**, press any button.
- NOTE: ULTIMATE CLEAN and TURBO will work while the AirDome™ 150 is in SLEEP MODE.**

- H Timer**
- Allows you to choose the AirDome™ 150's duration of operation from ½ hour, 1, 2, 4, 8, or 12 hours by setting a countdown timer to shut off the AirDome™ 150 or end the current function.
1. Press **TIMER**. The bar next to ½ hour will be lit. After pressing timer six times, all bars will be lit.
  2. Press **TIMER** once more to turn the **TIMER** off.

- I Reset Filter**
- The **CLEAN FILTER 2/3** light will illuminate indicating that the AirDome™ 150's Washable Air CAGE™ Filters 1 and 2 need to be cleaned. To reset the indicator light after cleaning the filters,
1. Press and hold **TIMER** for 2 seconds, until 2 beeps are heard and the **CLEAN FILTER 2/3 lights** turn off.

### COLOURS OF CLEAN FILTER 2/3 light:

- After about 3 months the **CLEAN FILTER 2/3 light** will turn **Yellow** alerting you that the Washable Air CAGE™ Filters 1 and 2 **SHOULD BE CLEANED** to maintain optimal performance.
- After about 6 months the **CLEAN FILTER 2/3 light** will turn **Orange** indicating that the Washable Air CAGE™ Filters 1 and 2 **SHOULD BE CLEANED**.
- After 12 months the **CLEAN FILTER 2/3 light** will turn **Red** indicating that the Washable Air CAGE™ Filters 1 and 2 **MUST BE CLEANED**.
- After the filters are cleaned and the indicator is reset, the first green bar around AIR will be lit.

- J Turbo**
- Allows you to operate the AirDome™ 150 at the highest fan speed 6 to clean the air for a selected duration of time from ½ hour, 1, or 2 hours. To add more time press **Timer**. (Cannot run with Fan Speed).
1. Press **TURBO** to select and set the duration of operation to ½ hour, 1, or 2 hours. When the selected time has finished, **TURBO** will shut off automatically.
  2. To exit **TURBO** mode, press **TURBO** until no bars are lit.

- K Mute**
- Press and hold **TURBO** for 2 seconds until 2 beeps are heard. Repeat to unmute.

# MAINTENANCE AND CLEANING

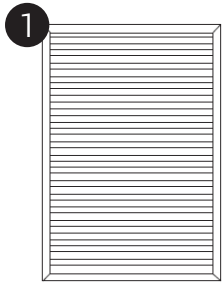

Washable Dust Filter

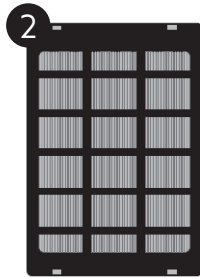

Washable Air CAGE™ Filter 1

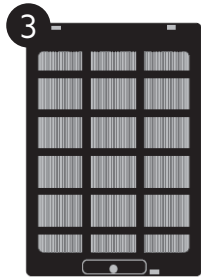

Washable Air CAGE™ Filter 2

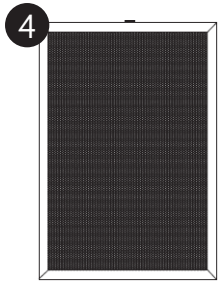

Carbon Ozone Filter



Air Activator™

## General Maintenance:

Regularly check and clean the air inlet and outlet for clear airflow using a soft brush or a slightly damp cloth.

## Device Cleaning:

Clean the exterior and control panel with a soft, damp cloth. Avoid using abrasive cleaners or harsh chemicals.

## Filter Cleaning Guidance:

Except for the Air Carbon Ozone Filter, all pre-filters and Air CAGE™ filters are washable with water.

## 1 Washable Dust Filter

## 2 + 3 Air CAGE™ Washable Filters:

These filters are washable with water. Clean as necessary based on air quality and usage, using mild detergent and water. Ensure they are fully dry before reinstalling.

- Rinse all Air CAGE™ filters under cool water.
- Use caution when cleaning the equipment because harsh detergents that are corrosive will scratch the surface.
- Always use soft cloths to gently wipe machine surfaces.
- Avoid using alcohol or other organic solvents to clean the device because doing so could harm it or result in electric shock, fire, etc.
- Please unplug the machine from the electrical outlet while cleaning or not using the machine, as doing so could result in an electric shock or a fire from a short circuit.
- Reassemble once all parts are dry.

## 4 Carbon Ozone Filter:

**Important: DO NOT WASH WITH WATER.**

- Use a vacuum cleaner or soft brush to remove dust and debris.

## 5 Air Activator™

Emits and automatically regulates advanced bipolar ions. Advanced air purification and sanitation technology developed in collaboration with A\*STAR.

For more detailed cleaning instructions, please visit our website [www.tridentair.com/support](http://www.tridentair.com/support)

## TROUBLESHOOTING

- **Device Not Powering On:** Check the power connection and ensure the filter cover is properly secured.
- **Reduced Purification Performance:** Inspect for any obstructions and verify that filters are clean and correctly installed.
- **Unusual Noise:** Ensure nothing has fallen inside the device and that it is placed on a stable surface.
- **Touch panel not responding; fan does not operate; other anomalies:** Power off and wait for 10 seconds before powering on again. If issues persist, please contact us.

## AIR QUALITY COLOUR DISPLAY

The current PM2.5 value will simultaneously be displayed in the display window on the control panel.

According to the current readings on PM2.5 condition, the **PM2.5 indicator light** above the front panel changes colour:

EXCELLENT

GOOD

MODERATE

POOR

According to the present state of gaseous pollutants, the **TVOC (Total Volatile Organic Compound) indicator light** on the control panel changes color:

EXCELLENT

GOOD

MODERATE

POOR

## TECHNICAL SPECIFICATIONS

Voltage	220V
Frequency	50Hz
Power	128W
Smoke CADR	1000 m <sup>3</sup> /h
Coverage	Up to 150sqm

## CUSTOMER SERVICE AND WARRANTY INFORMATION

### Warranty:

Enjoy a two-year standard warranty, with specific terms for on-site service during the first 30 days followed by carry-in service.

### Contact Details:

For assistance, email or call

- support@tridentair.com
- +65 9457 3681

This manual aims to provide detailed yet clear instructions for the setup and maintenance of your Trident AirDome™ 150 Purifier, leveraging advanced AirDome™ technology for superior air quality.

For additional support, refer to the customer service section or visit the Trident Air website at [www.tridentair.com/support](http://www.tridentair.com/support)







© 2024 Plasma Science Pte. Ltd. Information correct at time of print.  
Please refer to our website for latest updates and instruction manual editions.

For technical support or other enquiries,  
please email: [support@tridentair.com](mailto:support@tridentair.com), call: +65 9457 3681

Address: 7 Yishun Industrial Street 1 #03-49 North Spring Bizhub, Singapore 768162

All Rights Reserved.